

## The IHB LED family

IHB LED luminaires are the perfect replacement for 250-1,500+ watt HID and 2-10 lamp T8, T12 and T5HO fluorescent high bay fixtures. Designed for locations requiring continuous and consistent light levels, requiring frequent on-and-off of lights and that are difficult to re-lamp.

## Applications:

- Locations requiring continuous and consistent light levels
- Areas requiring frequent on-and-off of lights
- Areas that are difficult to re-lamp or that cause production to be stopped during the lamp maintenance process
- Ordinary clean, light industrial production facilities, packaging facilities and warehouses

## Features:

- High efficacy: up to 117 LPW
- 80 CRI
- Up to 67% energy savings over traditional HID fixtures
- Complete portfolio replaces 250-1,500+ watt HID and 2-8 lamp T8, T12 and T5HO fluorescent lamps
- Customer payback of 1-3 years and lower total cost of ownership compared to HID and fluorescent lighting
- Versatile mounting options
- Optional 0-10V dimming capabilities
- Damp location rated
- Operating ambient: -40°C to +60°C<sup>Ⓐ</sup>
- 5 year fixture warranty

## Certifications and compliances:

- UL1598 – Luminaires
- UL8750 – LED
- cULus
- Damp locations
- DesignLights Consortium® Qualified (some models are not DLC qualified)<sup>Ⓑ</sup>

## Standard materials:

- Housing and heat sinks – anodized aluminum
- LED assembly – polycarbonate
- Lens – tempered glass or polycarbonate

## Mounting options:

- 3/4" pendant mount
- Jack chain
- Aircraft cable

## Weights:

Model	Lbs.	Kg.
IHB16L	17.00	7.71
IHB24L	27.00	12.25
IHB32L	36.00	16.33
IHB48L	54.00	24.49
IHB64L	74.00	33.57



## Electrical ratings:

Model	Equivalent luminaires		At 120V					
	HID	Fluorescent	Voltage	PF	THD	Watts	Lumens <sup>Ⓒ</sup>	Efficacy
IHB16L	250W-500W	4-lamp T5HO	120	0.99	8%	145	16,900	117
IHB24L	400W-750W	4- to 6-lamp T5HO	120	0.99	7%	216	25,350	117
IHB32L	500W-1000W	6- to 8-lamp T5HO	120	0.99	8%	289	33,800	117
IHB48L	750W-1500W	8- to 10-lamp T5HO	120	0.99	8%	436	50,700	116
IHB64L	1000W-1500W+	10-lamp T5HO	120	0.99	8%	582	67,600	116

## Dimensions:

IHB16L

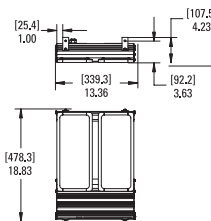

IHB48L

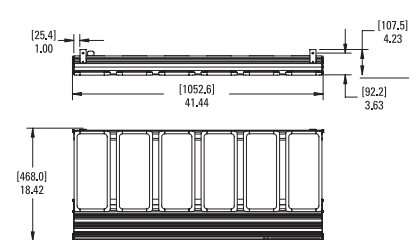

IHB24L

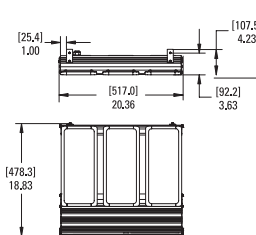

IHB64L

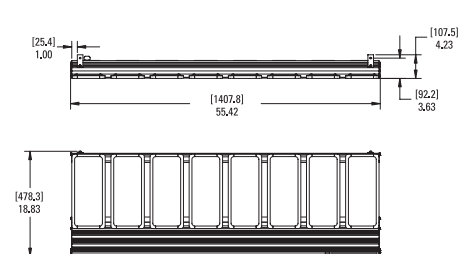

IHB32L

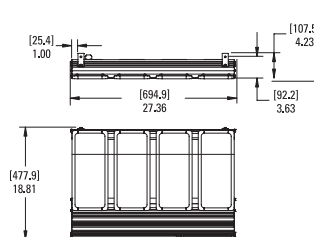

<sup>Ⓐ</sup> 5 year warranty at 40°C average operating ambient temperature.

<sup>Ⓑ</sup> Approved models include: IHB16L/UNV1; IHB16L/UNV34; IHB24L/UNV1; IHB24L/UNV34; IHB32L/UNV1; IHB32L/UNV34; IHB48L/UNV1; IHB48L/UNV34; IHB64L/UNV1; IHB64L/UNV34. Refer to [www.designlights.org](http://www.designlights.org) Qualified Products List under Family Models for full listing details. Not all models are approved for all application categories.

<sup>Ⓒ</sup> Preliminary typical values (+/- 10%); data subject to change. 8L option available; consult factory for availability.

**Reliable high bay solutions.** IHB LED luminaires are engineered to provide maintenance-free performance while delivering long life and high lumen performance.



#### Increased efficiency and durability

- Up to 117 lumens per watt
- Up to 67% energy savings over traditional HID fixtures

#### Multiple lens options

- Tempered, clear glass lens standard
- Diffused glass and clear or diffused polycarbonate lens options available



IHB16L



IHB32L



#### Superior thermal management

- Aluminum heat sinks designed to provide long life performance

#### Full portfolio of high bay solutions

- Complete portfolio replaces 250-1500+ watt HID and 2- to 10-lamp T8, T12 and T5HO fluorescent lamps

## Ordering information:

Part number example

**IHB16LP1R1/UNV1 S903**

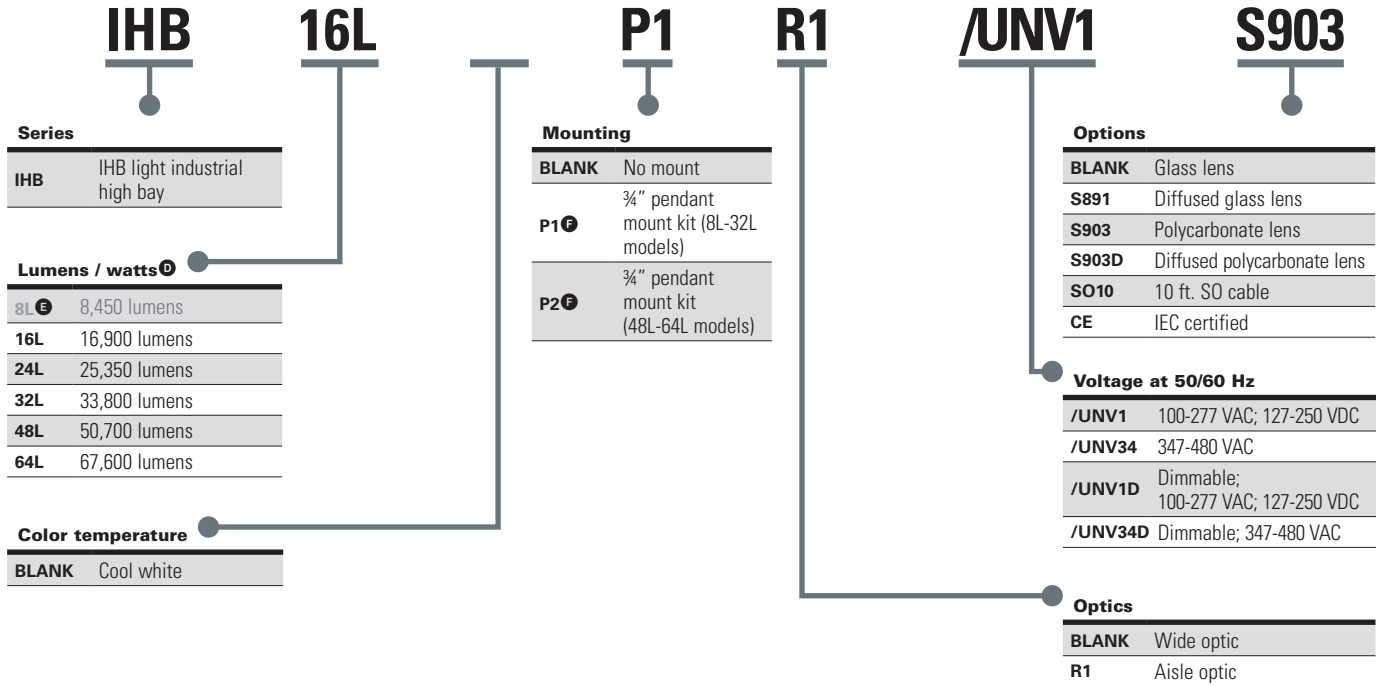

## Accessories:

### Mounting kits (ordered separately)

IHB P1 KIT	3/4" pendant mount kit (8L-32L)
IHB P2 KIT	3/4" pendant mount kit (48L-64L)
IHB P3 KIT	3/4" pendant mount kit for use with dust cover (8L-32L)
IHB P4 KIT	3/4" pendant mount kit for use with dust cover (48L-64L)
IHB J1 KIT	48" jack chain kit
IHB J2 KIT	72" jack chain kit
IHB J3 KIT	96" jack chain kit
IHB J4 KIT	120" jack chain kit
IHB J5 KIT	144" jack chain kit
IHB A1 KIT	40" aircraft cable kit
IHB A2 KIT	80" aircraft cable kit
IHB A3 KIT	120" aircraft cable kit
IHB A4 KIT	180" aircraft cable kit

### Dust cover kits (ordered separately)

IHB8L DC1 KIT	IHB8L dust cover kit, fully enclosed (1.2 lbs.)
IHB16L DC1 KIT	IHB16L dust cover kit, fully enclosed (1.6 lbs.)
IHB24L DC1 KIT	IHB24L dust cover kit, fully enclosed (2.5 lbs.)
IHB32L DC1 KIT	IHB32L dust cover kit, fully enclosed (3.3 lbs.)
IHB48L DC1 KIT	IHB48L dust cover kit, fully enclosed (5.0 lbs.)
IHB64L DC1 KIT	IHB64L dust cover kit, fully enclosed (6.4 lbs.)
IHB8L DC2 KIT	IHB8L dust cover kit, open ended (2.4 lbs.)
IHB16L DC2 KIT	IHB16L dust cover kit, open ended (2.7 lbs.)
IHB24L DC2 KIT	IHB24L dust cover kit, open ended (3.4 lbs.)
IHB32L DC2 KIT	IHB32L dust cover kit, open ended (4.1 lbs.)
IHB48L DC2 KIT	IHB48L dust cover kit, open ended (6.8 lbs.)
IHB64L DC2 KIT	IHB64L dust cover kit, open ended (8.6 lbs.)

### Replacement drivers (ordered separately)

<b>100-277 VAC; 127-250 VDC</b>	
IHB UNV1D 75W DRIVER KIT <sup>Ⓒ</sup>	Dimmable, 75W replacement driver
IHB UNV1D 150W DRIVER KIT <sup>Ⓓ</sup>	Dimmable, 150W replacement driver
<b>347-480 VAC</b>	
IHB UNV34D 75W DRIVER KIT <sup>Ⓒ</sup>	Dimmable, 75W replacement driver
IHB UNV34D 150W DRIVER KIT <sup>Ⓓ</sup>	Dimmable, 150W replacement driver

### Occupancy sensors (ordered separately)

Kit	Sensor lens	Mounting height (ft.)	Max. coverage diameter (ft.)	Light fixture
IHB C1 KIT	FSP-L2	8	48	8L
IHB C2 KIT	FSP-L3	20	40	16L, 24L, 32L, 48L, 64L
IHB C3 KIT	FSP-L4	40	60	48L, 64L
IHB C4 KIT	FSP-L7	40	100	48L, 64L
REMOTE CONTROL 1	Occupancy sensor remote control			

### Lens guard (ordered separately)

IHB G KIT	Lens guard (specify quantity; order one guard per 8L module, see table below)		
Model	Quantity	Model	Quantity
IHB8L	1	IHB32L	4
IHB16L	2	IHB48L	6
IHB24L	3	IHB64L	8

<sup>Ⓒ</sup> Typical values (+/- 10%); data subject to change.  
<sup>Ⓓ</sup> 8L option available; consult factory for availability.  
<sup>Ⓕ</sup> Not for use with dust covers. Order dust cover and matching pendant mount separately.  
<sup>Ⓒ</sup> 8L and 24L models (24L model uses a single 75W and a single 150W driver).  
<sup>Ⓓ</sup> 16L, 24L, 32L, 48L and 64L models (24L model uses a single 75W and a single 150W driver).

## Mounting options:

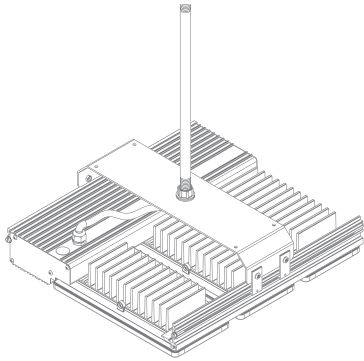

### Pendant mount

- P1 and P2 for use without dust cover; can be ordered separately or factory installed
- P3 and P4 for use with dust cover

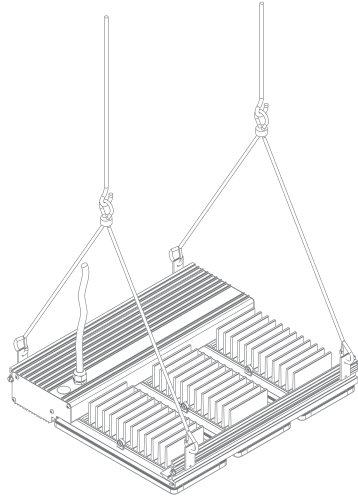

### Aircraft cable

- Ships separately from fixture
- For mounting with or without dust cover

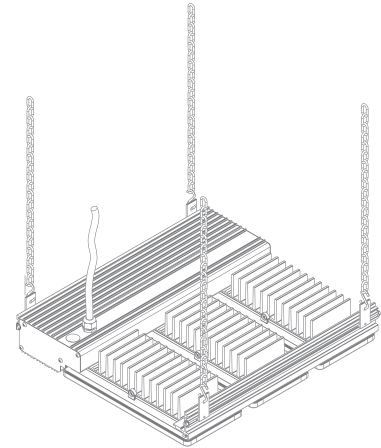

### Jack chain

- Ships separately from fixture
- For mounting with or without dust cover

## Accessories:

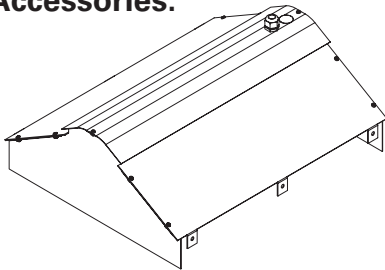

### DC-1 Fully enclosed dust cover

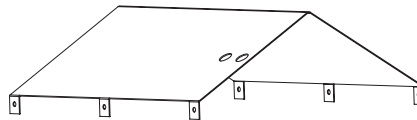

### DC-2 Open ended dust cover

### Dust covers

- Ship separately from fixture
- For pendant mount, use IHB P3 KIT (8L-32L models); IHB P4 KIT (48L-64L models)

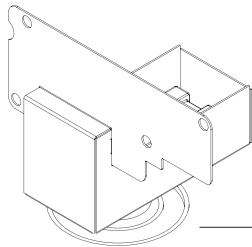

### IHB CX KIT Occupancy sensor

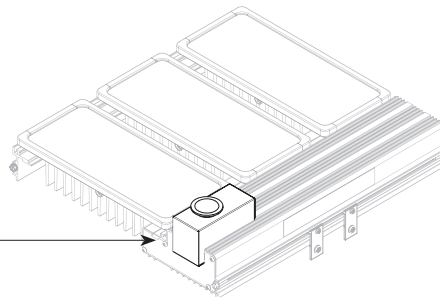

### IHB G KIT Lens guard

### Occupancy sensor and remote

- Ships separately from fixture; installation required
- Photocell and occupancy sensor customizable with remote control
- Remote control sold separately; only one required to program multiple light fixtures

### Lens guards

- Ship separately from fixture
- Order quantity differs by model

Model	Quantity
IHB8L	1
IHB16L	2
IHB24L	3

Model	Quantity
IHB32L	4
IHB48L	6
IHB64L	8