

Fiberglass Fittings Part Numbering

Example: ^{Prefix} **4 F SB - 12 - 90 HB 12** (9" rung spacing is standard)

Height	Material	Bottom	Width	Angle	Type	Radius
<ul style="list-style-type: none"> ● 3 = 3" ** ● 4 = 4" ● 6 = 6" ● 8 = 8" 	<ul style="list-style-type: none"> ● F = Polyester ● FV = Vinyl Ester ● FA☆ = Zero Halogen Dis-Stat 	<ul style="list-style-type: none"> ● Blank = Ladder Type ● SB = Solid Bottom† 	<ul style="list-style-type: none"> ● 06 = 6" (152) ● 09 = 9" (228) ● 12 = 12" (305) ● 18 = 18" (457) ● 24 = 24" (609) ● 30 = 30" (762) ● 36 = 36" (914) 	<ul style="list-style-type: none"> ● 45 = 45° ● 90 = 90° 	<ul style="list-style-type: none"> ● HB = Horizontal Bend ● HT = Horizontal Tee ● HX = Horizontal Cross ● VI = Vertical Inside Bend ● VO = Vertical Outside Bend ● LR = Left Reducer ● RR = Right Reducer ● SR = Straight Reducer 	<ul style="list-style-type: none"> ● 12 = 12" (305) ● 24 = 24" (609) ● 36 = 36" (914)

** 3" deep fittings are available in 6" thru 24" widths and 12" radius only.

† Solid bottom sheets ship separately with connecting hardware and assembled on site.

☆ Available in 6" height only.

● Green = Fastest shipped items ● Black = Normal lead-time items ● Red = Normally long lead-time items

Dimensions shown in parentheses are in millimeters, unless otherwise specified.

Horizontal Bend 90° (HB)

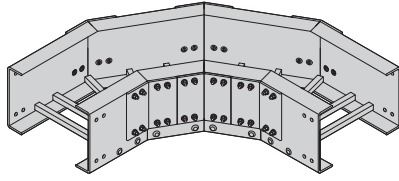

One pair of splice plates with SS6 hardware required to connect to system.

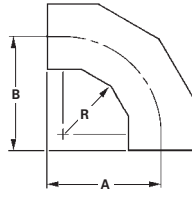

90° Mitered

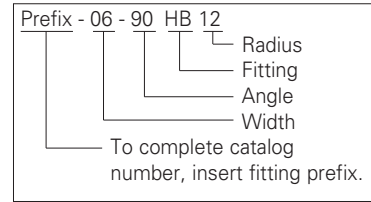

(Prefix) See page M-20 for catalog number prefix.
Dimensions for reference only, when critical contact factory.

- R - Bend Radius in. (mm)	Tray Width in. (mm)	90° Horizontal Bend - Mitered Dimensions				
		Catalog No.	A		B	
			in.	(mm)	in.	(mm)
12 (305)	6 (152)	(Prefix)-06-90HB12	28 ^{11/16}	(728)	28 ^{11/16}	(728)
	9 (228)	(Prefix)-09-90HB12	30 ^{3/16}	(767)	30 ^{3/16}	(767)
	12 (305)	(Prefix)-12-90HB12	31 ^{11/16}	(805)	31 ^{11/16}	(805)
	18 (457)	(Prefix)-18-90HB12	34 ^{11/16}	(881)	34 ^{11/16}	(881)
	24 (609)	(Prefix)-24-90HB12	37 ^{11/16}	(957)	37 ^{11/16}	(957)
	30 (762)	(Prefix)-30-90HB12	40 ^{11/16}	(1033)	40 ^{11/16}	(1033)
	36 (914)	(Prefix)-36-90HB12	43 ^{11/16}	(1109)	43 ^{11/16}	(1109)
24 (609)	6 (152)	(Prefix)-06-90HB24	41	(1041)	41	(1041)
	9 (228)	(Prefix)-09-90HB24	42 ^{1/2}	(1079)	42 ^{1/2}	(1079)
	12 (305)	(Prefix)-12-90HB24	44	(1117)	44	(1117)
	18 (457)	(Prefix)-18-90HB24	47	(1193)	47	(1193)
	24 (609)	(Prefix)-24-90HB24	50	(1269)	50	(1269)
	30 (762)	(Prefix)-30-90HB24	53	(1346)	53	(1346)
	36 (914)	(Prefix)-36-90HB24	56	(1422)	56	(1422)
36 (914)	6 (152)	(Prefix)-06-90HB36	53 ^{1/4}	(1353)	53 ^{1/4}	(1353)
	9 (228)	(Prefix)-09-90HB36	54 ^{3/4}	(1391)	54 ^{3/4}	(1391)
	12 (305)	(Prefix)-12-90HB36	56 ^{1/4}	(1429)	56 ^{1/4}	(1429)
	18 (457)	(Prefix)-18-90HB36	59 ^{1/4}	(1505)	59 ^{1/4}	(1505)
	24 (609)	(Prefix)-24-90HB36	62 ^{1/4}	(1582)	62 ^{1/4}	(1582)
	30 (762)	(Prefix)-30-90HB36	65 ^{1/4}	(1658)	65 ^{1/4}	(1658)
	36 (914)	(Prefix)-36-90HB36	68 ^{1/4}	(1734)	68 ^{1/4}	(1734)

For 3" Fittings

(Tray Widths - 6" thru 24" • Radius 12" only)
Polyester, Vinyl Ester
All are mitered

For 6" Fittings

(Tray Widths - 6" thru 36" • Radius 12", 24" & 36")
Polyester, Vinyl Ester, Zero Halogen/Dis-Stat
All radius are mitered

For 4" Fittings

(Tray Widths - 6" thru 36" • Radius 12", 24" & 36")
Polyester, Vinyl Ester
All radius are mitered

For 8" Fittings

(Tray Widths - 6" thru 36" • Radius 12", 24" & 36")
Polyester, Vinyl Ester
All radius are mitered

● Green = Fastest shipped items ● Black = Normal lead-time items ● Red = Normally long lead-time items

Dimensions shown in parentheses are in millimeters, unless otherwise specified.

Horizontal Bend 45° (HB)

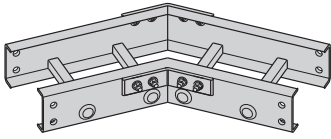

One pair of splice plates with SS6 hardware required to connect to system.

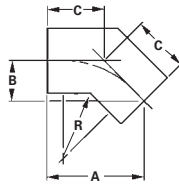

45° Mitered

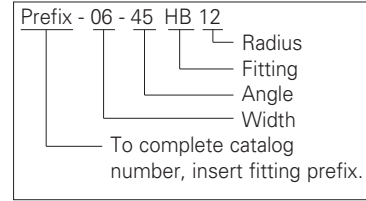

(Prefix) See page M-20 for catalog number prefix.
Dimensions for reference only, when critical contact factory.

- R - Bend Radius in. (mm)	Tray Width in. (mm)	45° Horizontal Bend - Mitered Dimensions			
		Catalog No.	A in. (mm)	B in. (mm)	C in. (mm)
12 (305)	6 (152)	(Prefix)-06-45HB12	24 ²¹ / ₃₂ (626)	10 ⁷ / ₃₂ (259)	14 ⁷ / ₁₆ (367)
	9 (228)	(Prefix)-09-45HB12	25 ²³ / ₃₂ (653)	10 ²¹ / ₃₂ (271)	15 ¹ / ₁₆ (383)
	12 (305)	(Prefix)-12-45HB12	26 ²⁵ / ₃₂ (680)	11 ³ / ₃₂ (282)	15 ¹¹ / ₁₈ (398)
	18 (457)	(Prefix)-18-45HB12	28 ²⁹ / ₃₂ (734)	11 ³¹ / ₃₂ (304)	16 ¹⁵ / ₁₆ (430)
	24 (609)	(Prefix)-24-45HB12	31 ¹ / ₃₂ (788)	12 ²⁷ / ₃₂ (326)	18 ⁵ / ₃₂ (462)
	30 (762)	(Prefix)-30-45HB12	33 ⁵ / ₃₂ (842)	13 ³ / ₄ (349)	19 ¹³ / ₃₂ (493)
	36 (914)	(Prefix)-36-45HB12	35 ¹ / ₄ (896)	14 ⁵ / ₈ (371)	20 ²¹ / ₃₂ (525)
24 (609)	6 (152)	(Prefix)-06-45HB12	24 ²¹ / ₃₂ (626)	10 ⁷ / ₃₂ (259)	14 ⁷ / ₁₆ (367)
	9 (228)	(Prefix)-09-45HB12	25 ²³ / ₃₂ (653)	10 ²¹ / ₃₂ (271)	15 ¹ / ₁₆ (383)
	12 (305)	(Prefix)-12-45HB12	26 ²⁵ / ₃₂ (680)	11 ³ / ₃₂ (282)	15 ¹¹ / ₁₈ (398)
	18 (457)	(Prefix)-18-45HB12	28 ²⁹ / ₃₂ (734)	11 ³¹ / ₃₂ (304)	16 ¹⁵ / ₁₆ (430)
	24 (609)	(Prefix)-24-45HB12	31 ¹ / ₃₂ (788)	12 ²⁷ / ₃₂ (326)	18 ⁵ / ₃₂ (462)
	30 (762)	(Prefix)-30-45HB12	33 ⁵ / ₃₂ (842)	13 ³ / ₄ (349)	19 ¹³ / ₃₂ (493)
	36 (914)	(Prefix)-36-45HB12	35 ¹ / ₄ (896)	14 ⁵ / ₈ (371)	20 ²¹ / ₃₂ (525)
36 (914)	6 (152)	(Prefix)-06-45HB12	24 ²¹ / ₃₂ (626)	10 ⁷ / ₃₂ (259)	14 ⁷ / ₁₆ (367)
	9 (228)	(Prefix)-09-45HB12	25 ²³ / ₃₂ (653)	10 ²¹ / ₃₂ (271)	15 ¹ / ₁₆ (383)
	12 (305)	(Prefix)-12-45HB12	26 ²⁵ / ₃₂ (680)	11 ³ / ₃₂ (282)	15 ¹¹ / ₁₈ (398)
	18 (457)	(Prefix)-18-45HB12	28 ²⁹ / ₃₂ (734)	11 ³¹ / ₃₂ (304)	16 ¹⁵ / ₁₆ (430)
	24 (609)	(Prefix)-24-45HB12	31 ¹ / ₃₂ (788)	12 ²⁷ / ₃₂ (326)	18 ⁵ / ₃₂ (462)
	30 (762)	(Prefix)-30-45HB12	33 ⁵ / ₃₂ (842)	13 ³ / ₄ (349)	19 ¹³ / ₃₂ (493)
	36 (914)	(Prefix)-36-45HB12	35 ¹ / ₄ (896)	14 ⁵ / ₈ (371)	20 ²¹ / ₃₂ (525)

For 3" Fittings

(Tray Widths - 6" thru 24" • Radius 12" only)
Polyester, Vinyl Ester
All are mitered

For 6" Fittings

(Tray Widths - 6" thru 36"
Radius 12", 24" & 36")
Polyester, Vinyl Ester, Zero Halogen/Dis-Stat
All radius are mitered

For 4" Fittings

(Tray Widths - 6" thru 36"
Radius 12", 24" & 36")
Polyester, Vinyl Ester
All radius are mitered

For 8" Fittings

(Tray Widths - 6" thru 36"
Radius 12", 24" & 36")
Polyester, Vinyl Ester
All radius are mitered

Dimensions shown in parentheses are in millimeters, unless otherwise specified.

Horizontal Tee (HT)

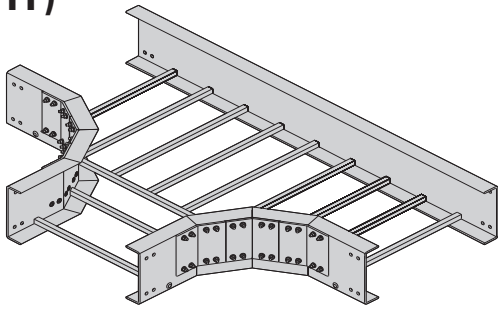

Two pair of splice plates with SS6 hardware required to connect to system.

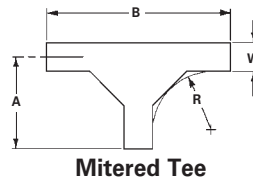

Mitered Tee

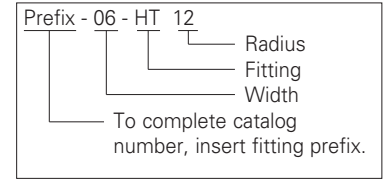

(Prefix) See page M-20 for catalog number prefix.
Dimensions for reference only, when critical contact factory.

- R - Bend Radius in. (mm)	Tray Width in. (mm)	Horizontal Tee - Mitered Dimensions		
		Catalog No.	A in. (mm)	B in. (mm)
12 (305)	6 (152)	(Prefix)-06-HT12	28 ⁷ / ₃₂ (716)	56 ¹³ / ₃₂ (1433)
	9 (228)	(Prefix)-09-HT12	29 ¹¹ / ₁₆ (754)	59 ¹³ / ₃₂ (1509)
	12 (305)	(Prefix)-12-HT12	31 ⁷ / ₃₂ (792)	62 ¹³ / ₃₂ (1585)
	18 (457)	(Prefix)-18-HT12	34 ⁷ / ₃₂ (869)	68 ¹³ / ₃₂ (1737)
	24 (609)	(Prefix)-24-HT12	37 ⁷ / ₃₂ (945)	74 ¹³ / ₃₂ (1890)
	30 (762)	(Prefix)-30-HT12	40 ⁷ / ₃₂ (1021)	80 ¹³ / ₃₂ (2042)
	36 (914)	(Prefix)-36-HT12	43 ⁷ / ₃₂ (1097)	86 ¹³ / ₃₂ (2195)
24 (609)	6 (152)	(Prefix)-06-HT24	40 ⁷ / ₃₂ (1021)	80 ¹³ / ₃₂ (2042)
	9 (228)	(Prefix)-09-HT24	41 ¹¹ / ₁₆ (1059)	83 ¹³ / ₃₂ (2118)
	12 (305)	(Prefix)-12-HT24	43 ⁷ / ₃₂ (1097)	86 ¹³ / ₃₂ (2195)
	18 (457)	(Prefix)-18-HT24	46 ⁷ / ₃₂ (1173)	92 ¹³ / ₃₂ (2347)
	24 (609)	(Prefix)-24-HT24	49 ⁷ / ₃₂ (1250)	98 ¹³ / ₃₂ (2499)
	30 (762)	(Prefix)-30-HT24	52 ⁷ / ₃₂ (1326)	104 ¹³ / ₃₂ (2652)
	36 (914)	(Prefix)-36-HT24	55 ⁷ / ₃₂ (1402)	110 ¹³ / ₃₂ (2804)
36 (914)	6 (152)	(Prefix)-06-HT36	52 ⁷ / ₃₂ (1326)	104 ¹³ / ₃₂ (2652)
	9 (228)	(Prefix)-09-HT36	53 ¹¹ / ₁₆ (1364)	107 ¹³ / ₃₂ (2728)
	12 (305)	(Prefix)-12-HT36	55 ⁷ / ₃₂ (1402)	110 ¹³ / ₃₂ (2804)
	18 (457)	(Prefix)-18-HT36	58 ⁷ / ₃₂ (1478)	116 ¹³ / ₃₂ (2957)
	24 (609)	(Prefix)-24-HT36	61 ⁷ / ₃₂ (1554)	122 ¹³ / ₃₂ (3109)
	30 (762)	(Prefix)-30-HT36	64 ⁷ / ₃₂ (1631)	128 ¹³ / ₃₂ (3261)
	36 (914)	(Prefix)-36-HT36	67 ⁷ / ₃₂ (1707)	134 ¹³ / ₃₂ (3414)

For 3" Fittings

(Tray Widths - 6" thru 24" • Radius 12" only)
Polyester, Vinyl Ester
All are mitered

For 6" Fittings

(Tray Widths - 6" thru 36" • Radius 12", 24" & 36")
Polyester, Vinyl Ester, Zero Halogen/Dis-Stat
All radius are mitered

For 4" Fittings

(Tray Widths - 6" thru 36" • Radius 12", 24" & 36")
Polyester, Vinyl Ester
All radius are mitered

For 8" Fittings

(Tray Widths - 6" thru 36" • Radius 12", 24" & 36")
Polyester, Vinyl Ester
All radius are mitered

Dimensions shown in parentheses are in millimeters, unless otherwise specified.

Horizontal Cross (HX)

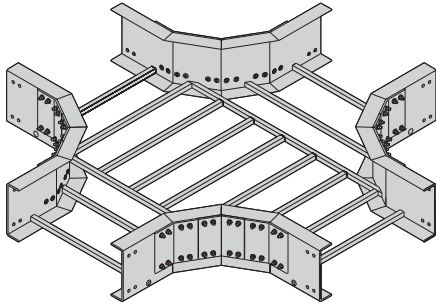

Three pair of splice plates with SS6 hardware required to connect to system.

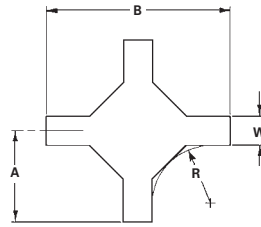

Mitered Cross

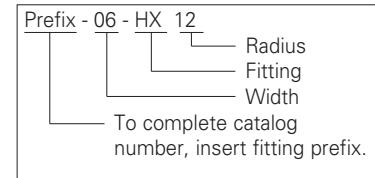

(Prefix) See page M-20 for catalog number prefix.
Dimensions for reference only, when critical contact factory.

- R - Bend Radius in. (mm)	Tray Width in. (mm)	Horizontal Cross - Mitered Dimensions		
		Catalog No.	A in. (mm)	B in. (mm)
12 (305)	6 (152)	(Prefix)-06-HX12	28 ³ / ₁₆ (716)	56 ¹³ / ₃₂ (1433)
	9 (228)	(Prefix)-09-HX12	29 ¹¹ / ₁₆ (754)	59 ¹³ / ₃₂ (1509)
	12 (305)	(Prefix)-12-HX12	31 ³ / ₁₆ (792)	62 ¹³ / ₃₂ (1585)
	18 (457)	(Prefix)-18-HX12	34 ³ / ₁₆ (869)	68 ¹³ / ₃₂ (1737)
	24 (609)	(Prefix)-24-HX12	37 ³ / ₁₆ (945)	74 ¹³ / ₃₂ (1890)
	30 (762)	(Prefix)-30-HX12	40 ³ / ₁₆ (1021)	80 ¹³ / ₃₂ (2042)
24 (609)	6 (152)	(Prefix)-06-HX24	40 ³ / ₁₆ (1021)	80 ¹³ / ₃₂ (2042)
	9 (228)	(Prefix)-09-HX24	41 ¹¹ / ₁₆ (1059)	83 ¹³ / ₃₂ (2118)
	12 (305)	(Prefix)-12-HX24	43 ³ / ₁₆ (1097)	86 ¹³ / ₃₂ (2195)
	18 (457)	(Prefix)-18-HX24	46 ³ / ₁₆ (1173)	92 ¹³ / ₃₂ (2347)
	24 (609)	(Prefix)-24-HX24	49 ³ / ₁₆ (1250)	98 ¹³ / ₃₂ (2499)
	30 (762)	(Prefix)-30-HX24	52 ³ / ₁₆ (1326)	104 ¹³ / ₃₂ (2652)
36 (914)	6 (152)	(Prefix)-06-HX36	52 ³ / ₁₆ (1326)	104 ¹³ / ₃₂ (2652)
	9 (228)	(Prefix)-09-HX36	53 ¹¹ / ₁₆ (1364)	107 ¹³ / ₃₂ (2728)
	12 (305)	(Prefix)-12-HX36	55 ³ / ₁₆ (1402)	110 ¹³ / ₃₂ (2804)
	18 (457)	(Prefix)-18-HX36	58 ³ / ₁₆ (1478)	116 ¹³ / ₃₂ (2957)
	24 (609)	(Prefix)-24-HX36	61 ³ / ₁₆ (1554)	122 ¹³ / ₃₂ (3109)
	30 (762)	(Prefix)-30-HX36	64 ³ / ₁₆ (1631)	128 ¹³ / ₃₂ (3261)
	36 (914)	(Prefix)-36-HX36	67 ³ / ₁₆ (1707)	134 ¹³ / ₃₂ (3414)

For 3" Fittings

(Tray Widths - 6" thru 24" • Radius 12" only)
Polyester, Vinyl Ester
All are mitered

For 6" Fittings

(Tray Widths - 6" thru 36"
Radius 12", 24" & 36")
Polyester, Vinyl Ester, Zero Halogen/Dis-Stat
All radius are mitered

For 4" Fittings

(Tray Widths - 6" thru 36"
Radius 12", 24" & 36")
Polyester, Vinyl Ester
All radius are mitered

For 8" Fittings

(Tray Widths - 6" thru 36"
Radius 12", 24" & 36")
Polyester, Vinyl Ester
All radius are mitered

Dimensions shown in parentheses are in millimeters, unless otherwise specified.

Reducers (LR) (SR) (RR)

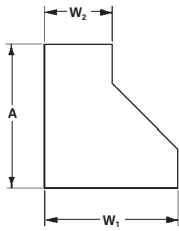
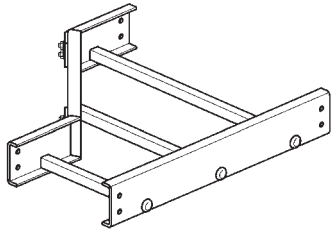

Left Reducer

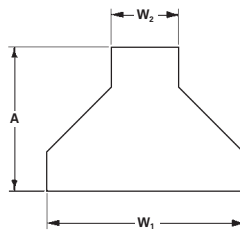
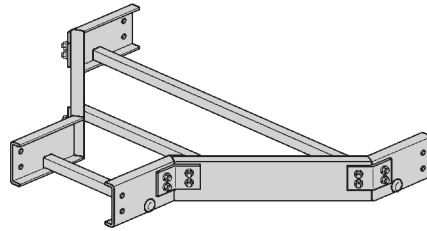

Straight Reducer

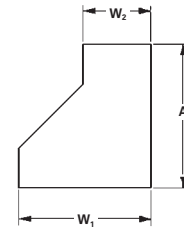
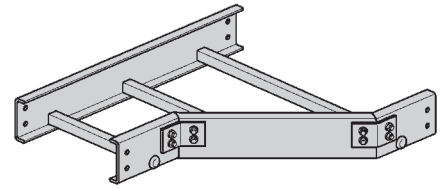

Right Reducer

One pair of splice plates with SS6 hardware required to connect to system.

3" Fittings

(Only available in W_1 widths of 9", 12", 18" & 24")

4", 6" & 8" Fittings

(Available in all W_1 widths shown in chart)

Reducers are all of mitered construction.

Polyester, Vinyl Ester
Available in all heights

Zero Halogen/Dis-Stat
Available in 6" height only

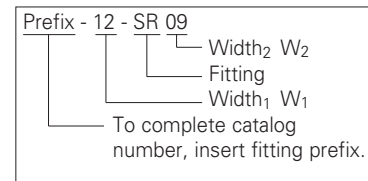

(Prefix) See page M-20 for catalog number prefix.
Dimensions for reference only, when critical contact factory.

Tray Width		Left Hand Reducer		Straight Reducer		Right Hand Reducer	
W_1 in. (mm)	W_2 in. (mm)	Catalog No.	A in. (mm)	Catalog No.	A in. (mm)	Catalog No.	A in. (mm)
9 (228)	6 (152)	(Prefix)-09-LR06	21 (533)	(Prefix)-09-SR06	19 1/2 (495)	(Prefix)-09-RR06	21 (533)
	12 (305)	(Prefix)-12-LR06	24 (609)	(Prefix)-12-SR06	21 (533)	(Prefix)-12-RR06	24 (609)
18 (457)	9 (228)	(Prefix)-12-LR09	21 (533)	(Prefix)-12-SR09	19 1/2 (495)	(Prefix)-12-RR09	21 (533)
	6 (152)	(Prefix)-18-LR06	30 (762)	(Prefix)-18-SR06	24 (609)	(Prefix)-18-RR06	30 (762)
	9 (228)	(Prefix)-18-LR09	27 (686)	(Prefix)-18-SR09	22 1/2 (571)	(Prefix)-18-RR09	27 (686)
24 (609)	12 (305)	(Prefix)-18-LR12	24 (609)	(Prefix)-18-SR12	21 (533)	(Prefix)-18-RR12	24 (609)
	6 (152)	(Prefix)-24-LR06	36 (914)	(Prefix)-24-SR06	27 (686)	(Prefix)-24-RR06	36 (914)
	9 (228)	(Prefix)-24-LR09	33 (838)	(Prefix)-24-SR09	25 1/2 (648)	(Prefix)-24-RR09	33 (838)
	12 (305)	(Prefix)-24-LR12	30 (762)	(Prefix)-24-SR12	24 (609)	(Prefix)-24-RR12	30 (762)
30 (762)	18 (457)	(Prefix)-24-LR18	24 (609)	(Prefix)-24-SR18	21 (533)	(Prefix)-24-RR18	24 (609)
	6 (152)	(Prefix)-30-LR06	42 (1067)	(Prefix)-30-SR06	30 (762)	(Prefix)-30-RR06	42 (1067)
	9 (228)	(Prefix)-30-LR09	39 (990)	(Prefix)-30-SR09	28 1/2 (724)	(Prefix)-30-RR09	39 (990)
	12 (305)	(Prefix)-30-LR12	36 (914)	(Prefix)-30-SR12	27 (686)	(Prefix)-30-RR12	36 (914)
	18 (457)	(Prefix)-30-LR18	30 (762)	(Prefix)-30-SR18	24 (609)	(Prefix)-30-RR18	30 (762)
36 (914)	24 (609)	(Prefix)-30-LR24	24 (609)	(Prefix)-30-SR24	21 (533)	(Prefix)-30-RR24	24 (609)
	6 (152)	(Prefix)-36-LR06	48 (1219)	(Prefix)-36-SR06	33 (838)	(Prefix)-36-RR06	48 (1219)
	9 (228)	(Prefix)-36-LR09	45 (1143)	(Prefix)-36-SR09	31 1/2 (800)	(Prefix)-36-RR09	45 (1143)
	12 (305)	(Prefix)-36-LR12	42 (1067)	(Prefix)-36-SR12	30 (762)	(Prefix)-36-RR12	42 (1067)
	18 (457)	(Prefix)-36-LR18	36 (914)	(Prefix)-36-SR18	27 (686)	(Prefix)-36-RR18	36 (914)
	24 (609)	(Prefix)-36-LR24	30 (762)	(Prefix)-36-SR24	24 (609)	(Prefix)-36-RR24	30 (762)
36 (914)	30 (762)	(Prefix)-36-LR30	24 (609)	(Prefix)-36-SR30	21 (533)	(Prefix)-36-RR30	24 (609)

Dimensions shown in parentheses are in millimeters, unless otherwise specified.

Horizontal Reducing Tee (HT)

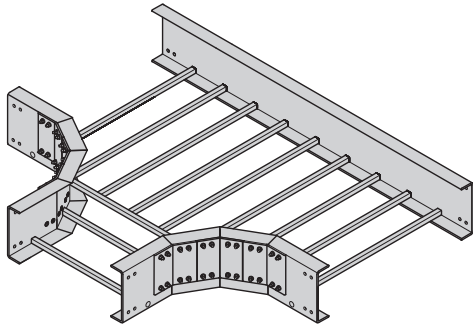

Two pair of splice plates with SS6 hardware required to connect to system.

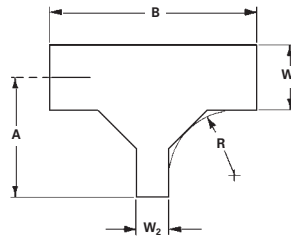

Mitered Reducing Tee

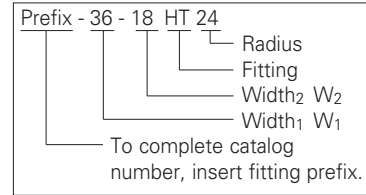

(Prefix) See page M-20 for catalog number prefix.
Dimensions for reference only, when critical contact factory.

Mitered Fittings

Tray Width		Catalog No. * Insert radius (12", 24" or 36")	12" Radius (305)		24" Radius (609)		36" Radius (914)	
W ₁ in. (mm)	W ₂ in. (mm)		A in. (mm)	B in. (mm)	A in. (mm)	B in. (mm)	A in. (mm)	B in. (mm)
9 (228)	6 (152)	(Prefix)-09-06-HT*	29 ¹¹ / ₁₆ (754)	56 ¹³ / ₃₂ (1433)	41 ¹¹ / ₁₆ (1059)	80 ¹³ / ₃₂ (2042)	53 ¹¹ / ₁₆ (1364)	104 ¹³ / ₃₂ (2652)
12 (305)	6 (152)	(Prefix)-12-06-HT*	31 ³ / ₁₆ (792)	56 ¹³ / ₃₂ (1433)	43 ³ / ₁₆ (1097)	80 ¹³ / ₃₂ (2042)	55 ³ / ₁₆ (1402)	104 ¹³ / ₃₂ (2652)
	9 (228)	(Prefix)-12-09-HT*	31 ³ / ₁₆ (792)	59 ¹³ / ₃₂ (1509)	43 ³ / ₁₆ (1097)	83 ¹³ / ₃₂ (2118)	55 ³ / ₁₆ (1402)	107 ¹³ / ₃₂ (2728)
18 (457)	6 (152)	(Prefix)-18-06-HT*	34 ³ / ₁₆ (869)	56 ¹³ / ₃₂ (1433)	46 ³ / ₁₆ (1173)	80 ¹³ / ₃₂ (2042)	58 ³ / ₁₆ (1478)	104 ¹³ / ₃₂ (2652)
	9 (228)	(Prefix)-18-09-HT*	34 ³ / ₁₆ (869)	59 ¹³ / ₃₂ (1509)	46 ³ / ₁₆ (1173)	83 ¹³ / ₃₂ (2118)	58 ³ / ₁₆ (1478)	107 ¹³ / ₃₂ (2728)
	12 (305)	(Prefix)-18-12-HT*	34 ³ / ₁₆ (869)	62 ¹³ / ₃₂ (1585)	46 ³ / ₁₆ (1173)	86 ¹³ / ₃₂ (2195)	58 ³ / ₁₆ (1478)	110 ¹³ / ₃₂ (2804)
24 (609)	6 (152)	(Prefix)-24-06-HT*	37 ³ / ₁₆ (945)	56 ¹³ / ₃₂ (1433)	49 ³ / ₁₆ (1250)	80 ¹³ / ₃₂ (2042)	61 ³ / ₁₆ (1554)	104 ¹³ / ₃₂ (2652)
	9 (228)	(Prefix)-24-09-HT*	37 ³ / ₁₆ (945)	59 ¹³ / ₃₂ (1509)	49 ³ / ₁₆ (1250)	83 ¹³ / ₃₂ (2118)	61 ³ / ₁₆ (1554)	107 ¹³ / ₃₂ (2728)
	12 (305)	(Prefix)-24-12-HT*	37 ³ / ₁₆ (945)	62 ¹³ / ₃₂ (1585)	49 ³ / ₁₆ (1250)	86 ¹³ / ₃₂ (2195)	61 ³ / ₁₆ (1554)	110 ¹³ / ₃₂ (2804)
	18 (457)	(Prefix)-24-18-HT*	37 ³ / ₁₆ (945)	68 ¹³ / ₃₂ (1737)	49 ³ / ₁₆ (1250)	92 ¹³ / ₃₂ (2347)	61 ³ / ₁₆ (1554)	116 ¹³ / ₃₂ (2957)
30 (762)	6 (152)	(Prefix)-30-06-HT*	40 ³ / ₁₆ (1021)	56 ¹³ / ₃₂ (1433)	52 ³ / ₁₆ (1326)	80 ¹³ / ₃₂ (2042)	64 ³ / ₁₆ (1631)	104 ¹³ / ₃₂ (2652)
	9 (228)	(Prefix)-30-09-HT*	40 ³ / ₁₆ (1021)	59 ¹³ / ₃₂ (1509)	52 ³ / ₁₆ (1326)	83 ¹³ / ₃₂ (2118)	64 ³ / ₁₆ (1631)	107 ¹³ / ₃₂ (2728)
	12 (305)	(Prefix)-30-12-HT*	40 ³ / ₁₆ (1021)	62 ¹³ / ₃₂ (1585)	52 ³ / ₁₆ (1326)	86 ¹³ / ₃₂ (2195)	64 ³ / ₁₆ (1631)	110 ¹³ / ₃₂ (2804)
	18 (457)	(Prefix)-30-18-HT*	40 ³ / ₁₆ (1021)	68 ¹³ / ₃₂ (1737)	52 ³ / ₁₆ (1326)	92 ¹³ / ₃₂ (2347)	64 ³ / ₁₆ (1631)	116 ¹³ / ₃₂ (2957)
	24 (609)	(Prefix)-30-24-HT*	40 ³ / ₁₆ (1021)	74 ¹³ / ₃₂ (1890)	52 ³ / ₁₆ (1326)	98 ¹³ / ₃₂ (2499)	64 ³ / ₁₆ (1631)	122 ¹³ / ₃₂ (3109)
36 (914)	6 (152)	(Prefix)-36-06-HT*	43 ³ / ₁₆ (1097)	56 ¹³ / ₃₂ (1433)	55 ³ / ₁₆ (1402)	80 ¹³ / ₃₂ (2042)	67 ³ / ₁₆ (1707)	104 ¹³ / ₃₂ (2652)
	9 (228)	(Prefix)-36-09-HT*	43 ³ / ₁₆ (1097)	59 ¹³ / ₃₂ (1509)	55 ³ / ₁₆ (1402)	83 ¹³ / ₃₂ (2118)	67 ³ / ₁₆ (1707)	107 ¹³ / ₃₂ (2728)
	12 (305)	(Prefix)-36-12-HT*	43 ³ / ₁₆ (1097)	62 ¹³ / ₃₂ (1585)	55 ³ / ₁₆ (1402)	86 ¹³ / ₃₂ (2195)	67 ³ / ₁₆ (1707)	110 ¹³ / ₃₂ (2804)
	18 (457)	(Prefix)-36-18-HT*	43 ³ / ₁₆ (1097)	68 ¹³ / ₃₂ (1737)	55 ³ / ₁₆ (1402)	92 ¹³ / ₃₂ (2347)	67 ³ / ₁₆ (1707)	116 ¹³ / ₃₂ (2957)
	24 (609)	(Prefix)-36-24-HT*	43 ³ / ₁₆ (1097)	74 ¹³ / ₃₂ (1890)	55 ³ / ₁₆ (1402)	98 ¹³ / ₃₂ (2499)	67 ³ / ₁₆ (1707)	122 ¹³ / ₃₂ (3109)
	30 (762)	(Prefix)-36-30-HT*	43 ³ / ₁₆ (1097)	80 ¹³ / ₃₂ (2042)	55 ³ / ₁₆ (1402)	104 ¹³ / ₃₂ (2652)	67 ³ / ₁₆ (1707)	128 ¹³ / ₃₂ (3261)

For 3" Fittings

(Radius 12" only
W₁ tray widths - 9", 12", 18" & 24")
Polyester, Vinyl Ester
All are mitered

For 4" Fittings

(Radius 12", 24" & 36"
W₁ tray widths - 9" thru 36")
Polyester, Vinyl Ester
All radius are mitered

For 6" Fittings

(Radius 12", 24" & 36"
W₁ tray widths - 9" thru 36")
Polyester, Vinyl Ester, Zero Halogen/Dis-Stat
All radius are mitered

For 8" Fittings

(Radius 12", 24" & 36"
W₁ tray widths - 9" thru 36")
Polyester, Vinyl Ester
All radius are mitered

Dimensions shown in parentheses are in millimeters, unless otherwise specified.

Horizontal Expanding Tee (HT)

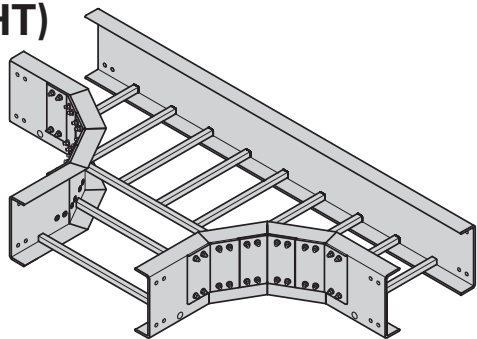

Two pair of splice plates with SS6 hardware required to connect to system.

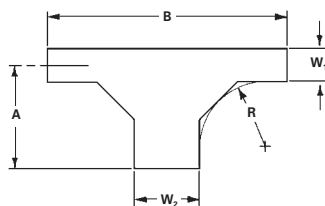

Mitered

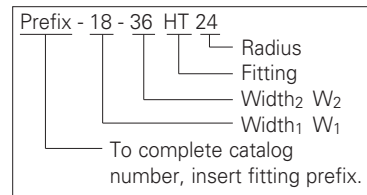

(Prefix) See page M-20 for catalog number prefix.
Dimensions for reference only, when critical contact factory.

Mitered Fittings

Tray Width		Catalog No. * Insert radius (12", 24" or 36")	12" Radius (305)		24" Radius (609)		36" Radius (914)	
W ₁ in. (mm)	W ₂ in. (mm)		A in. (mm)	B in. (mm)	A in. (mm)	B in. (mm)	A in. (mm)	B in. (mm)
6 (152)	9 (228)	(Prefix)-06-09-HT*	28 ³ / ₁₆ (716)	59 ¹³ / ₃₂ (1509)	40 ³ / ₁₆ (1021)	83 ¹³ / ₃₂ (2118)	52 ³ / ₁₆ (1326)	107 ¹³ / ₃₂ (2728)
	12 (305)	(Prefix)-06-12-HT*	28 ³ / ₁₆ (716)	62 ¹³ / ₃₂ (1585)	40 ³ / ₁₆ (1021)	86 ¹³ / ₃₂ (2195)	52 ³ / ₁₆ (1326)	110 ¹³ / ₃₂ (2804)
	18 (457)	(Prefix)-06-18-HT*	28 ³ / ₁₆ (716)	68 ¹³ / ₃₂ (1737)	40 ³ / ₁₆ (1021)	92 ¹³ / ₃₂ (2347)	52 ³ / ₁₆ (1326)	116 ¹³ / ₃₂ (2957)
	24 (609)	(Prefix)-06-24-HT*	28 ³ / ₁₆ (716)	74 ¹³ / ₃₂ (1890)	40 ³ / ₁₆ (1021)	98 ¹³ / ₃₂ (2499)	52 ³ / ₁₆ (1326)	122 ¹³ / ₃₂ (3109)
	30 (762)	(Prefix)-06-30-HT*	28 ³ / ₁₆ (716)	80 ¹³ / ₃₂ (2042)	40 ³ / ₁₆ (1021)	104 ¹³ / ₃₂ (2652)	52 ³ / ₁₆ (1326)	128 ¹³ / ₃₂ (3261)
	36 (914)	(Prefix)-06-36-HT*	28 ³ / ₁₆ (716)	86 ¹³ / ₃₂ (2195)	40 ³ / ₁₆ (1021)	110 ¹³ / ₃₂ (2804)	52 ³ / ₁₆ (1326)	134 ¹³ / ₃₂ (3414)
9 (228)	12 (305)	(Prefix)-09-12-HT*	29 ¹¹ / ₁₆ (754)	62 ¹³ / ₃₂ (1585)	41 ¹¹ / ₁₆ (1059)	86 ¹³ / ₃₂ (2195)	53 ¹¹ / ₁₆ (1364)	110 ¹³ / ₃₂ (2804)
	18 (457)	(Prefix)-09-18-HT*	29 ¹¹ / ₁₆ (754)	68 ¹³ / ₃₂ (1737)	41 ¹¹ / ₁₆ (1059)	92 ¹³ / ₃₂ (2347)	53 ¹¹ / ₁₆ (1364)	116 ¹³ / ₃₂ (2957)
	24 (609)	(Prefix)-09-24-HT*	29 ¹¹ / ₁₆ (754)	74 ¹³ / ₃₂ (1890)	41 ¹¹ / ₁₆ (1059)	98 ¹³ / ₃₂ (2499)	53 ¹¹ / ₁₆ (1364)	122 ¹³ / ₃₂ (3109)
	30 (762)	(Prefix)-09-30-HT*	29 ¹¹ / ₁₆ (754)	80 ¹³ / ₃₂ (2042)	41 ¹¹ / ₁₆ (1059)	104 ¹³ / ₃₂ (2652)	53 ¹¹ / ₁₆ (1364)	128 ¹³ / ₃₂ (3261)
	36 (914)	(Prefix)-09-36-HT*	29 ¹¹ / ₁₆ (754)	86 ¹³ / ₃₂ (2195)	41 ¹¹ / ₁₆ (1059)	110 ¹³ / ₃₂ (2804)	53 ¹¹ / ₁₆ (1364)	134 ¹³ / ₃₂ (3414)
12 (305)	18 (457)	(Prefix)-12-18-HT*	31 ³ / ₁₆ (792)	68 ¹³ / ₃₂ (1737)	43 ³ / ₁₆ (1097)	92 ¹³ / ₃₂ (2347)	55 ³ / ₁₆ (1402)	116 ¹³ / ₃₂ (2957)
	24 (609)	(Prefix)-12-24-HT*	31 ³ / ₁₆ (792)	74 ¹³ / ₃₂ (1890)	43 ³ / ₁₆ (1097)	98 ¹³ / ₃₂ (2499)	55 ³ / ₁₆ (1402)	122 ¹³ / ₃₂ (3109)
	30 (762)	(Prefix)-12-30-HT*	31 ³ / ₁₆ (792)	80 ¹³ / ₃₂ (2042)	43 ³ / ₁₆ (1097)	104 ¹³ / ₃₂ (2652)	55 ³ / ₁₆ (1402)	128 ¹³ / ₃₂ (3261)
	36 (914)	(Prefix)-12-36-HT*	31 ³ / ₁₆ (792)	86 ¹³ / ₃₂ (2195)	43 ³ / ₁₆ (1097)	110 ¹³ / ₃₂ (2804)	55 ³ / ₁₆ (1402)	134 ¹³ / ₃₂ (3414)
18 (457)	24 (609)	(Prefix)-18-24-HT*	34 ³ / ₁₆ (869)	74 ¹³ / ₃₂ (1890)	46 ³ / ₁₆ (1173)	98 ¹³ / ₃₂ (2499)	58 ³ / ₁₆ (1478)	122 ¹³ / ₃₂ (3109)
	30 (762)	(Prefix)-18-30-HT*	34 ³ / ₁₆ (869)	80 ¹³ / ₃₂ (2042)	46 ³ / ₁₆ (1173)	104 ¹³ / ₃₂ (2652)	58 ³ / ₁₆ (1478)	128 ¹³ / ₃₂ (3261)
	36 (914)	(Prefix)-18-36-HT*	34 ³ / ₁₆ (869)	86 ¹³ / ₃₂ (2195)	46 ³ / ₁₆ (1173)	110 ¹³ / ₃₂ (2804)	58 ³ / ₁₆ (1478)	134 ¹³ / ₃₂ (3414)
24 (609)	30 (762)	(Prefix)-24-30-HT*	37 ³ / ₁₆ (945)	80 ¹³ / ₃₂ (2042)	49 ³ / ₁₆ (1250)	104 ¹³ / ₃₂ (2652)	61 ³ / ₁₆ (1554)	128 ¹³ / ₃₂ (3261)
	36 (914)	(Prefix)-24-36-HT*	37 ³ / ₁₆ (945)	86 ¹³ / ₃₂ (2195)	49 ³ / ₁₆ (1250)	110 ¹³ / ₃₂ (2804)	61 ³ / ₁₆ (1554)	134 ¹³ / ₃₂ (3414)
30 (762)	36 (914)	(Prefix)-30-36-HT*	40 ³ / ₁₆ (1021)	86 ¹³ / ₃₂ (2195)	52 ³ / ₁₆ (1326)	110 ¹³ / ₃₂ (2804)	64 ³ / ₁₆ (1631)	134 ¹³ / ₃₂ (3414)

For 3" Fittings

(Radius 12" only)
W₁ tray widths - 6" thru 18"
W₂ tray widths - 9" thru 24"
Polyester, Vinyl Ester
All are mitered

For 4" Fittings

(Radius 12", 24" & 36")
W₁ tray widths - 6" thru 30"
W₂ tray widths - 9" thru 36"
Polyester, Vinyl Ester
All radius are mitered

For 6" Fittings

(Radius 12", 24" & 36")
W₁ tray widths - 6" thru 30"
W₂ tray widths - 9" thru 36"
Polyester, Vinyl Ester, Zero Halogen/Dis-Stat
All radius are mitered

For 8" Fittings

(Radius 12", 24" & 36")
W₁ tray widths - 6" thru 30"
W₂ tray widths - 9" thru 36"
Polyester, Vinyl Ester
All radius are mitered

Dimensions shown in parentheses are in millimeters, unless otherwise specified.

Horizontal Expanding/Reducing Cross (HX)

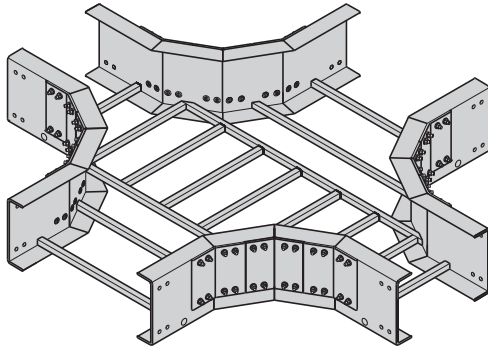

Three pair of splice plates with SS6 hardware required to connect to system.

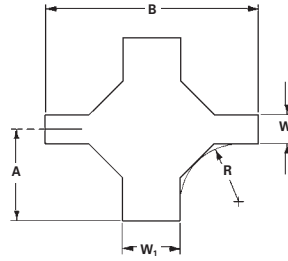

Mitered

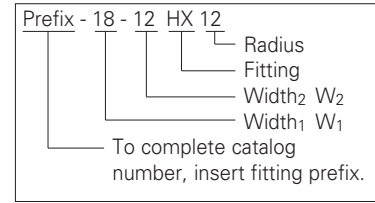

(Prefix) See page M-20 for catalog number prefix.
Dimensions for reference only, when critical contact factory.

Mitered Fittings

Tray Width		Catalog No. * Insert radius (12", 24" or 36")	12" Radius (305)		24" Radius (609)		36" Radius (914)	
W ₁ in. (mm)	W ₂ in. (mm)		A in. (mm)	B in. (mm)	A in. (mm)	B in. (mm)	A in. (mm)	B in. (mm)
9 (228)	6 (152)	(Prefix)-09-06-HX*	28 ³ / ₁₆ (716)	59 ¹³ / ₃₂ (1509)	40 ³ / ₁₆ (1021)	83 ¹³ / ₃₂ (2118)	52 ³ / ₁₆ (1326)	107 ¹³ / ₃₂ (2728)
12 (305)	6 (152)	(Prefix)-12-06-HX*	28 ³ / ₁₆ (716)	62 ¹³ / ₃₂ (1585)	40 ³ / ₁₆ (1021)	86 ¹³ / ₃₂ (2195)	52 ³ / ₁₆ (1326)	110 ¹³ / ₃₂ (2804)
	9 (228)	(Prefix)-12-09-HX*	29 ¹¹ / ₁₆ (754)	62 ¹³ / ₃₂ (1585)	41 ¹¹ / ₁₆ (1059)	86 ¹³ / ₃₂ (2195)	53 ¹¹ / ₁₆ (1364)	110 ¹³ / ₃₂ (2804)
18 (457)	6 (152)	(Prefix)-18-06-HX*	28 ³ / ₁₆ (716)	68 ¹³ / ₃₂ (1737)	40 ³ / ₁₆ (1021)	92 ¹³ / ₃₂ (2347)	52 ³ / ₁₆ (1326)	116 ¹³ / ₃₂ (2957)
	9 (228)	(Prefix)-18-09-HX*	29 ¹¹ / ₁₆ (754)	68 ¹³ / ₃₂ (1737)	41 ¹¹ / ₁₆ (1059)	92 ¹³ / ₃₂ (2347)	53 ¹¹ / ₁₆ (1364)	116 ¹³ / ₃₂ (2957)
	12 (305)	(Prefix)-18-12-HX*	31 ³ / ₁₆ (792)	68 ¹³ / ₃₂ (1737)	43 ³ / ₁₆ (1097)	92 ¹³ / ₃₂ (2347)	55 ³ / ₁₆ (1402)	116 ¹³ / ₃₂ (2957)
24 (609)	6 (152)	(Prefix)-24-06-HX*	28 ³ / ₁₆ (716)	74 ¹³ / ₃₂ (1890)	40 ³ / ₁₆ (1021)	98 ¹³ / ₃₂ (2499)	52 ³ / ₁₆ (1326)	122 ¹³ / ₃₂ (3109)
	9 (228)	(Prefix)-24-09-HX*	29 ¹¹ / ₁₆ (754)	74 ¹³ / ₃₂ (1890)	41 ¹¹ / ₁₆ (1059)	98 ¹³ / ₃₂ (2499)	53 ¹¹ / ₁₆ (1364)	122 ¹³ / ₃₂ (3109)
	12 (305)	(Prefix)-24-12-HX*	31 ³ / ₁₆ (792)	74 ¹³ / ₃₂ (1890)	43 ³ / ₁₆ (1097)	98 ¹³ / ₃₂ (2499)	55 ³ / ₁₆ (1402)	122 ¹³ / ₃₂ (3109)
	18 (457)	(Prefix)-24-18-HX*	34 ³ / ₁₆ (869)	74 ¹³ / ₃₂ (1890)	46 ³ / ₁₆ (1173)	98 ¹³ / ₃₂ (2499)	58 ³ / ₁₆ (1478)	122 ¹³ / ₃₂ (3109)
30 (762)	6 (152)	(Prefix)-30-06-HX*	28 ³ / ₁₆ (716)	80 ¹³ / ₃₂ (2042)	40 ³ / ₁₆ (1021)	104 ¹³ / ₃₂ (2652)	52 ³ / ₁₆ (1326)	128 ¹³ / ₃₂ (3261)
	9 (228)	(Prefix)-30-09-HX*	29 ¹¹ / ₁₆ (754)	80 ¹³ / ₃₂ (2042)	41 ¹¹ / ₁₆ (1059)	104 ¹³ / ₃₂ (2652)	53 ¹¹ / ₁₆ (1364)	128 ¹³ / ₃₂ (3261)
	12 (305)	(Prefix)-30-12-HX*	31 ³ / ₁₆ (792)	80 ¹³ / ₃₂ (2042)	43 ³ / ₁₆ (1097)	104 ¹³ / ₃₂ (2652)	55 ³ / ₁₆ (1402)	128 ¹³ / ₃₂ (3261)
	18 (457)	(Prefix)-30-18-HX*	34 ³ / ₁₆ (869)	80 ¹³ / ₃₂ (2042)	46 ³ / ₁₆ (1173)	104 ¹³ / ₃₂ (2652)	58 ³ / ₁₆ (1478)	128 ¹³ / ₃₂ (3261)
	24 (609)	(Prefix)-30-24-HX*	37 ³ / ₁₆ (945)	80 ¹³ / ₃₂ (2042)	49 ³ / ₁₆ (1250)	104 ¹³ / ₃₂ (2652)	61 ³ / ₁₆ (1554)	128 ¹³ / ₃₂ (3261)
36 (914)	6 (152)	(Prefix)-36-06-HX*	28 ³ / ₁₆ (716)	86 ¹³ / ₃₂ (2195)	40 ³ / ₁₆ (1021)	110 ¹³ / ₃₂ (2804)	52 ³ / ₁₆ (1326)	134 ¹³ / ₃₂ (3414)
	9 (228)	(Prefix)-36-09-HX*	29 ¹¹ / ₁₆ (754)	86 ¹³ / ₃₂ (2195)	41 ¹¹ / ₁₆ (1059)	110 ¹³ / ₃₂ (2804)	53 ¹¹ / ₁₆ (1364)	134 ¹³ / ₃₂ (3414)
	12 (305)	(Prefix)-36-12-HX*	31 ³ / ₁₆ (792)	86 ¹³ / ₃₂ (2195)	43 ³ / ₁₆ (1097)	110 ¹³ / ₃₂ (2804)	55 ³ / ₁₆ (1402)	134 ¹³ / ₃₂ (3414)
	18 (457)	(Prefix)-36-18-HX*	34 ³ / ₁₆ (869)	86 ¹³ / ₃₂ (2195)	46 ³ / ₁₆ (1173)	110 ¹³ / ₃₂ (2804)	58 ³ / ₁₆ (1478)	134 ¹³ / ₃₂ (3414)
	24 (609)	(Prefix)-36-24-HX*	37 ³ / ₁₆ (945)	86 ¹³ / ₃₂ (2195)	49 ³ / ₁₆ (1250)	110 ¹³ / ₃₂ (2804)	61 ³ / ₁₆ (1554)	134 ¹³ / ₃₂ (3414)
	30 (762)	(Prefix)-36-30-HX*	40 ³ / ₁₆ (1021)	86 ¹³ / ₃₂ (2195)	52 ³ / ₁₆ (1326)	110 ¹³ / ₃₂ (2804)	64 ³ / ₁₆ (1631)	134 ¹³ / ₃₂ (3414)

For 3" Fittings

(Radius 12" only
W₁ tray widths - 9" thru 24"
W₂ tray widths - 6" thru 18")
Polyester, Vinyl Ester
All are mitered

For 4" Fittings

(Radius 12", 24" & 36"
W₁ tray widths - 9" thru 36"
W₂ tray widths - 6" thru 30")
Polyester, Vinyl Ester
All radius are mitered

For 6" Fittings

(Radius 12", 24" & 36"
W₁ tray widths - 9" thru 36"
W₂ tray widths - 6" thru 30")
Polyester, Vinyl Ester, Zero Halogen/Dis-Stat
All radius are mitered

For 8" Fittings

(Radius 12", 24" & 36"
W₁ tray widths - 9" thru 36"
W₂ tray widths - 6" thru 30")
Polyester, Vinyl Ester
All radius are mitered

Dimensions shown in parentheses are in millimeters, unless otherwise specified.

Fiberglass - Fittings

Vertical Bends 90° (VO) (VI)

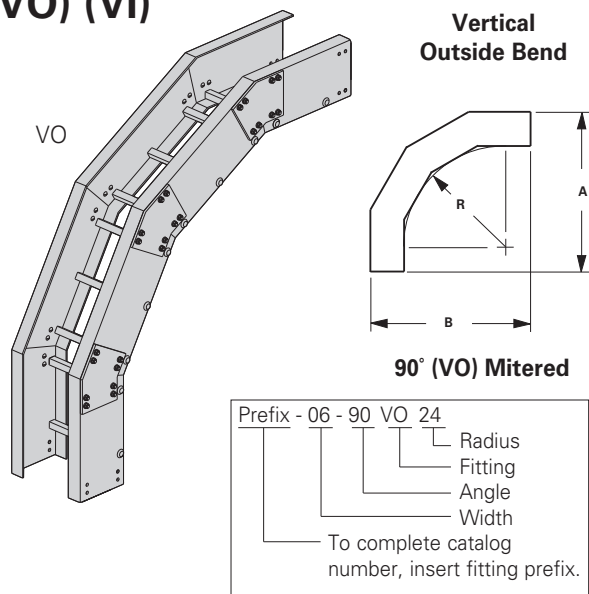

One pair of splice plates with SS6 hardware required to connect to system.

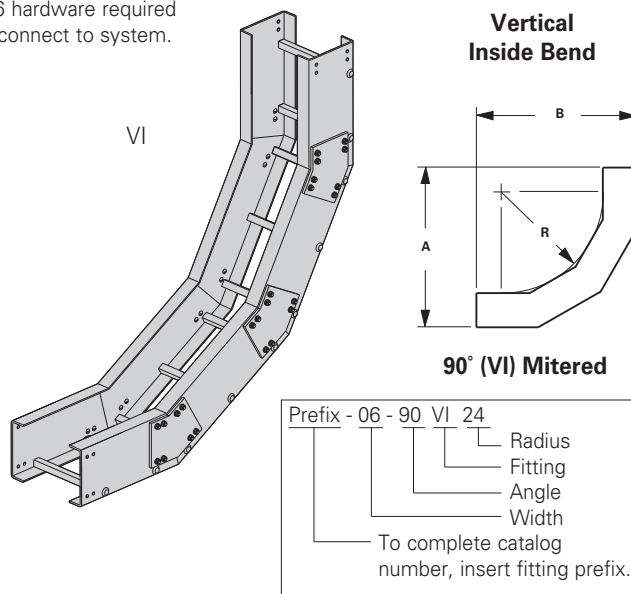

(Prefix) See page M-20 for catalog number prefix. Dimensions for reference only, when critical contact factory.

- R - Bend Radius in. (mm)	Tray Width in. (mm)	90° Mitered		
		Catalog No.	VO & VI Bend	
			A in. / (mm)	B in. / (mm)
12 (305)	6 (152)	(Prefix)-06-90(*)12	27 ⁵ / ₃₂ (690)	27 ⁵ / ₃₂ (690)
	9 (228)	(Prefix)-09-90(*)12		
	12 (305)	(Prefix)-12-90(*)12		
	18 (457)	(Prefix)-18-90(*)12		
	24 (609)	(Prefix)-24-90(*)12		
	36 (914)	(Prefix)-36-90(*)12		
24 (609)	6 (152)	(Prefix)-06-90(*)24	36 ²³ / ₃₂ (933)	36 ²³ / ₃₂ (933)
	9 (228)	(Prefix)-09-90(*)24		
	12 (305)	(Prefix)-12-90(*)24		
	18 (457)	(Prefix)-18-90(*)24		
	24 (609)	(Prefix)-24-90(*)24		
	36 (914)	(Prefix)-36-90(*)24		
36 (914)	6 (152)	(Prefix)-06-90(*)36	44 ²⁹ / ₃₂ (1141)	44 ²⁹ / ₃₂ (1141)
	9 (228)	(Prefix)-09-90(*)36		
	12 (305)	(Prefix)-12-90(*)36		
	18 (457)	(Prefix)-18-90(*)36		
	24 (609)	(Prefix)-24-90(*)36		
	36 (914)	(Prefix)-36-90(*)36		

For 3" Fittings
(Radius 12" only • Tray widths - 6" thru 24")
Polyester, Vinyl Ester
All are mitered

For 4" Fittings
(Radius 12", 24" & 36"
Tray widths - 6" thru 36")
Polyester, Vinyl Ester
All radius are mitered

For 6" Fittings
(Radius 12", 24" & 36"
Tray widths - 6" thru 36")
Polyester, Vinyl Ester, Zero Halogen/Dis-Stat
All radius are mitered

For 8" Fittings
(Radius 12", 24" & 36"
Tray widths - 6" thru 36")
Polyester, Vinyl Ester
All radius are mitered

(*) Insert 'VO' for Vertical Outside Bend or 'VI' for Vertical Inside Bend.

Dimensions shown in parentheses are in millimeters, unless otherwise specified.

Vertical Outside Bend

VO

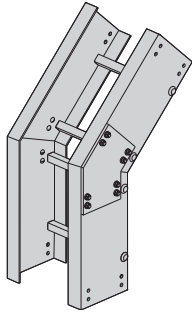

One pair of splice plates with SS6 hardware required to connect to system.

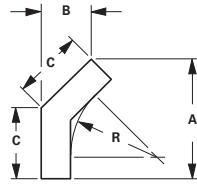

45° (VO) Mitered

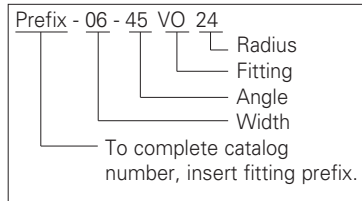

Vertical Inside Bend

VI

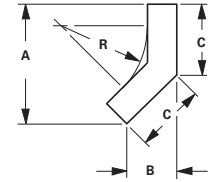
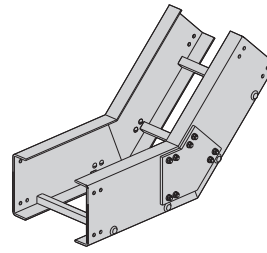

45° (VI) Mitered

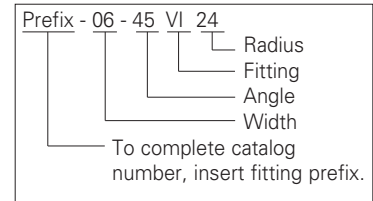

(Prefix) See page M-20 for catalog number prefix. Dimensions for reference only, when critical contact factory.

- R - Bend Radius in. mm	Tray Width in. mm	45° Mitered			
		Catalog No.	VO & VI Bend		
			A in. / (mm)	B in. / (mm)	C in. / (mm)
12 (305)	6 (152)	(Prefix)-06-45(*)12	23 ¹ / ₁₆ (585)	9 ⁹ / ₁₆ (242)	13 ¹ / ₂ (343)
	9 (228)	(Prefix)-09-45(*)12			
	12 (305)	(Prefix)-12-45(*)12			
	18 (457)	(Prefix)-18-45(*)12			
	24 (609)	(Prefix)-24-45(*)12			
	30 (762)	(Prefix)-30-45(*)12			
36 (914)	(Prefix)-36-45(*)12				
24 (609)	6 (152)	(Prefix)-06-45(*)24	23 ¹ / ₁₆ (585)	9 ⁹ / ₁₆ (242)	13 ¹ / ₂ (343)
	9 (228)	(Prefix)-09-45(*)24			
	12 (305)	(Prefix)-12-45(*)24			
	18 (457)	(Prefix)-18-45(*)24			
	24 (609)	(Prefix)-24-45(*)24			
	30 (762)	(Prefix)-30-45(*)24			
36 (914)	(Prefix)-36-45(*)24				
36 (914)	6 (152)	(Prefix)-06-45(*)36	23 ¹ / ₁₆ (585)	9 ⁹ / ₁₆ (242)	13 ¹ / ₂ (343)
	9 (228)	(Prefix)-09-45(*)36			
	12 (305)	(Prefix)-12-45(*)36			
	18 (457)	(Prefix)-18-45(*)36			
	24 (609)	(Prefix)-24-45(*)36			
	30 (762)	(Prefix)-30-45(*)36			
36 (914)	(Prefix)-36-45(*)36				

For 3" Fittings

(Radius 12" only • Tray widths - 6" thru 24")
Polyester, Vinyl Ester
All are mitered

For 4" Fittings

(Radius 12", 24" & 36"
Tray widths - 6" thru 36")
Polyester, Vinyl Ester
All radius are mitered

For 6" Fittings

(Radius 12", 24" & 36"
Tray widths - 6" thru 36")
Polyester, Vinyl Ester, Zero Halogen/Dis-Stat
All radius are mitered

For 8" Fittings

(Radius 12", 24" & 36"
Tray widths - 6" thru 36")
Polyester, Vinyl Ester
All radius are mitered

(*) Insert 'VO' for Vertical Outside Bend or 'VI' for Vertical Inside Bend.
60° and 30° vertical bends available in mitered construction.

Dimensions shown in parentheses are in millimeters, unless otherwise specified.